

# TOWN OF MEEKER, CO

## PAVING PROJECT

### 11th Street & 12th Street

PREPARED BY:

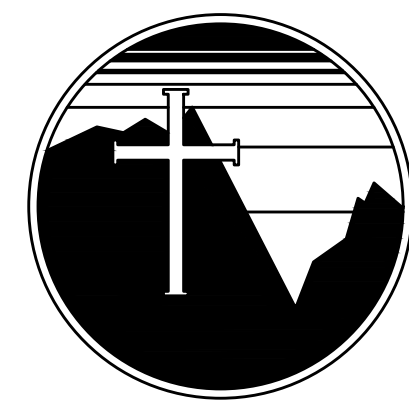

**MOUNTAIN CROSS ENGINEERING, INC.**  
 Civil and Environmental Consulting and Design  
 826 1/2 Grand Avenue Glenwood Springs, CO 81601  
 ph 970.945.5544 fx 970.945.5558 www.mountaincross-eng.com

**SurvCo, Inc.**

PO Box 2782, Glenwood Springs, CO 81602  
 PHONE: (970) 945-5945 CELL: (970) 379-7399

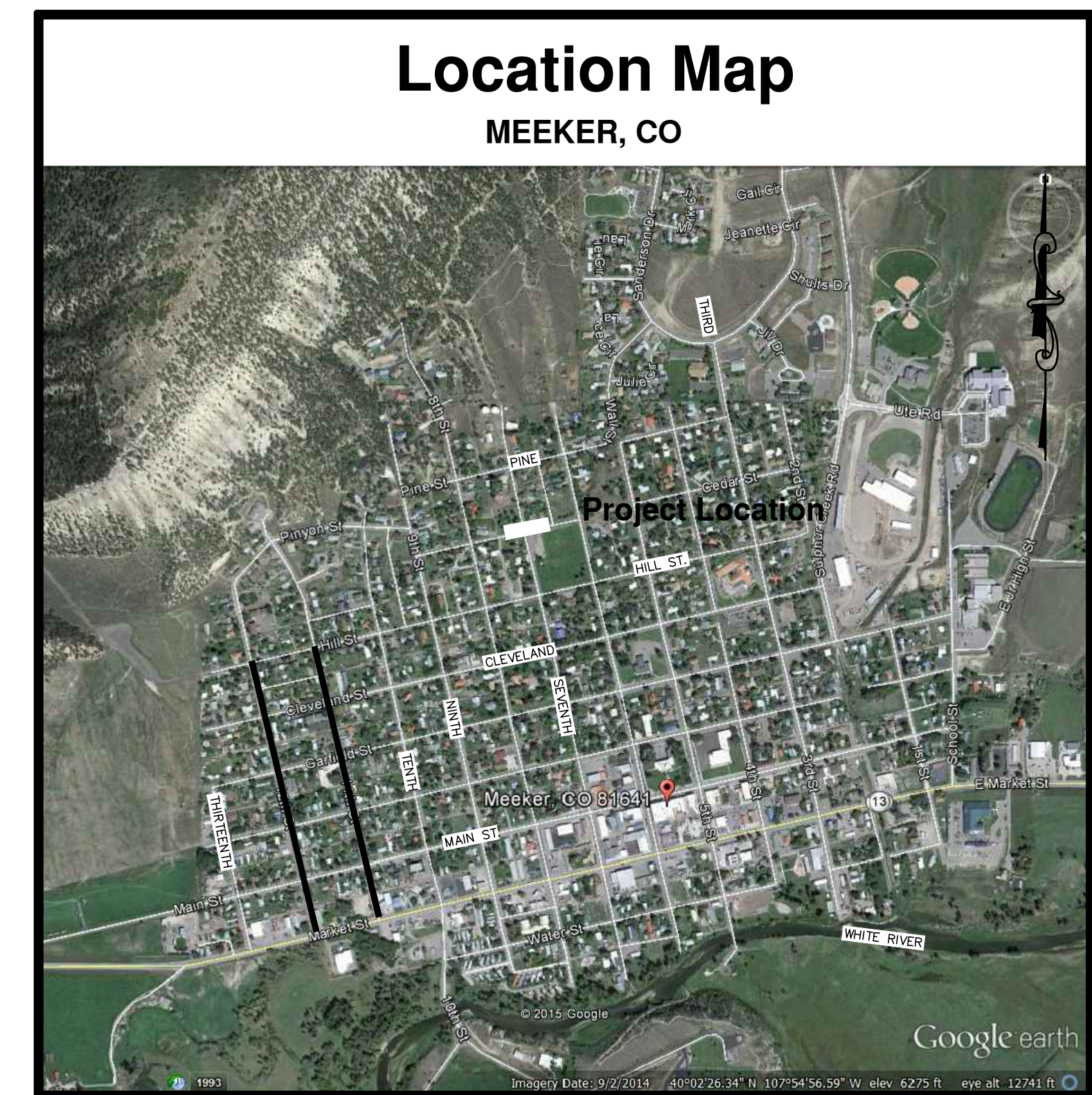

GENERAL NOTES:

1. ALL EXISTING IMPROVEMENTS, INCLUDING SIDEWALKS, PAVEMENT, TURF GRASS, LANDSCAPING, CULVERT PIPES, SIGNS, MAILBOXES, DRAINAGE, ETC. SHALL BE RETURNED TO THEIR ORIGINAL CONDITION. ALL DISTURBED EMBANKMENT AREAS SHALL BE SEEDED AND MULCHED; EXISTING TURF GRASS SHALL BE REPLACED WITH SOD. FINISH GRADING SHALL MAINTAIN DRAINAGE.
2. MINIMIZE THE TIME THAT DRIVEWAY ACCESSSES ARE CLOSED. PROVIDE ALTERNATIVE ACCESS WHERE FEASIBLE.
3. REPAINTING THE PAVEMENT STRIPING IS TO BE DONE BY OTHERS.
4. ROAD CLOSURES AND SIGNAGE TO BE BY THE MANUAL OF UNIFORM TRAFFIC CONTROL DEVICES (MUTCD).
5. MONUMENTS MAY EXIST. COORDINATE WITH RUSS OVERTON FOR RECONSTRUCTION.
6. RIGHT-OF-WAY IN THE TOWN OF MEEKER IS PER OFFICIAL TOWN MAP. CONTRACTOR TO LIMIT DISTURBANCE TO AREAS WITHIN RIGHT-OF-WAY.
7. EXISTING UNDERGROUND UTILITY LINES ARE TO BE EXPECTED. CONTRACTOR TO COORDINATE WITH THE RESPECTIVE UTILITY COMPANIES AND SHALL VERIFY BY POTHOLING ALL UTILITY LOCATIONS PRIOR TO BEGINNING WORK. CONTRACTOR RESPONSIBLE FOR ANY DAMAGE TO UTILITY LINES.
8. CONSTRUCTION ACTIVITIES MAY ONLY CLOSE EVERY OTHER INTERSECTION. NO ADJACENT, CONSECUTIVE INTERSECTIONS MAY BE CLOSED AT ANY TIME.
9. PLANS ARE BASED ON FIELD MEASUREMENTS AND ARE UNDERSTOOD TO BE SCHEMATIC. THE LOCATION OF IMPROVEMENTS ARE INTENDED TO SHOW GENERAL LOCATIONS, NOT EXACT LOCATIONS. ACTUAL LENGTHS, LOCATIONS, AND EXTENTS OF IMPROVEMENTS TO BE VERIFIED IN THE FIELD AND INSTALLED PER THEIR INTENT. COORDINATE WITH RUSS OVERTON #970.878.5530 TO FIELD VERIFY ALL IMPROVEMENTS PRIOR TO CONSTRUCTION.

**DRAWING LIST:**

1. Cover Sheet
2. 11th Street: Hill Street to Market Street
3. 12th Street: Hill Street to Market Street
4. Concrete Replacement: 11th St. & 12th St.
5. Details

**MOUNTAIN CROSS ENGINEERING, INC.**  
 Civil and Environmental Consulting and Design  
 826 1/2 Grand Avenue Glenwood Springs, CO 81601  
 ph 970.945.5544 fx 970.945.5558 www.mountaincross-eng.com

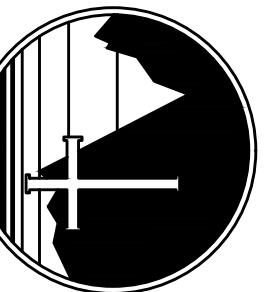

**PAVING PROJECT**  
**11th Street & 12th Street**  
**COVER SHEET**



REVISIONS	DATE	BY	COMMENTS

DATE 04/03/23

SCALE Not to Scale

ENGINEER C. HALE

DWG FILE 11th12thPaving

JOB 319-058

SHEET



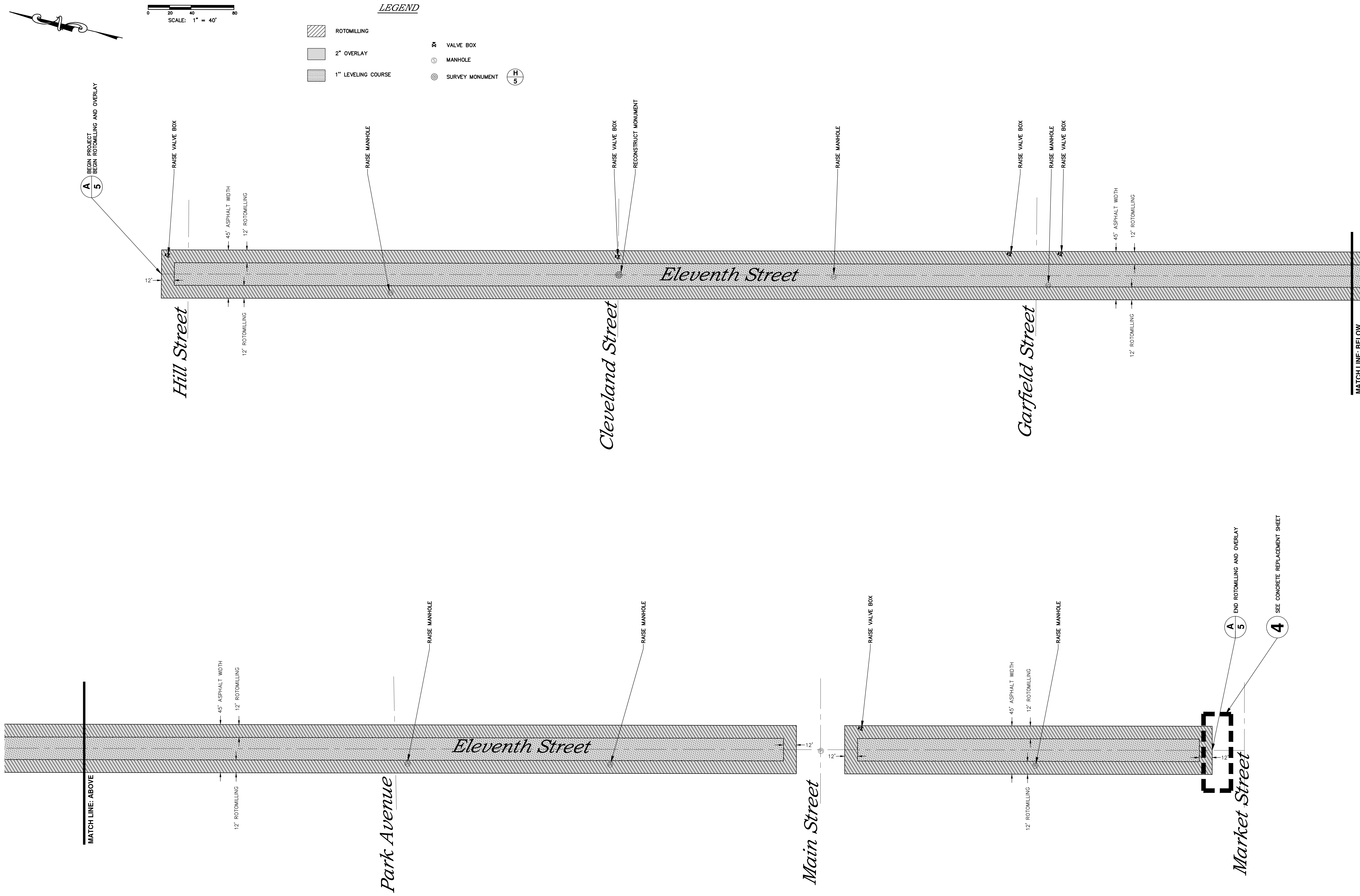

**A**  
**5**  
BEGIN PROJECT  
BEGIN ROTOMILLING AND OVERLAY

**A**  
**5**  
END ROTOMILLING AND OVERLAY

**4**  
SEE CONCRETE REPLACEMENT SHEET

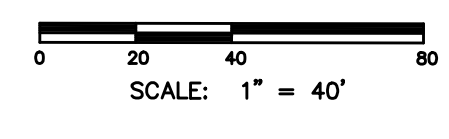

**LEGEND**

- ROTOMILLING
- 2" OVERLAY
- 1" LEVELING COURSE
- VALVE BOX
- MANHOLE
- SURVEY MONUMENT

MATCH LINE: BELOW

MATCH LINE: ABOVE

**MOUNTAIN CROSS ENGINEERING, INC.**  
Civil and Environmental Consulting and Design  
826 1/2 Grand Avenue Glenwood Springs, CO 81601  
ph 970.945.5544 fx 970.945.5558 www.mountaincross-eng.com

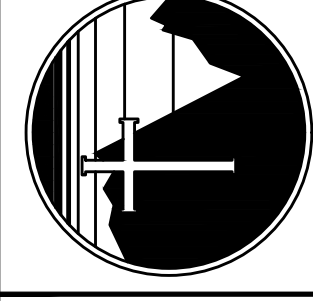

**PAVING PROJECT**  
**Eleventh Street:**  
**Hill Street to Market Street**

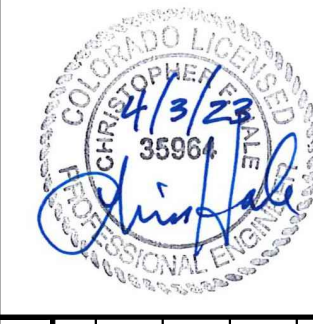

REVISIONS	DATE	BY	COMMENTS

DATE 04/03/23  
SCALE 1"=40'  
ENGINEER C. HALE  
DWG FILE 11th12thPaving  
JOB 319-058  
SHEET



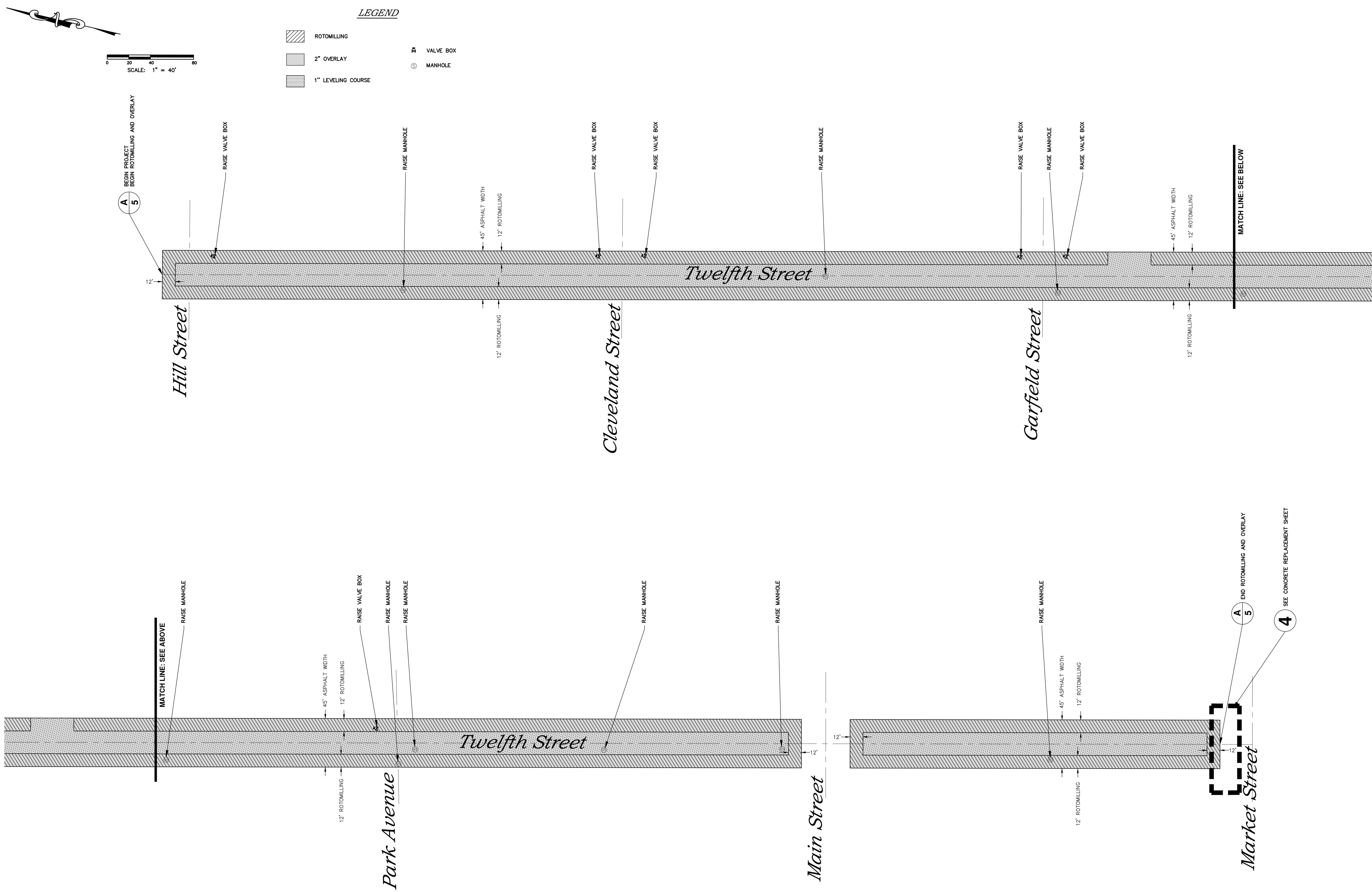

0 20 40 80  
SCALE: 1" = 40'

**LEGEND**

- ROTOMILLING
- 2" OVERLAY
- 1" LEVELING COURSE
- VALVE BOX
- MANHOLE



REVISIONS	DATE	BY	COMMENTS

DATE: 04/03/23  
SCALE: 1" = 40'  
ENGINEER: C. HALE  
DWG FILE: 11th12thPaving  
JOB: 319-058  
SHEET: 3

**PAVING PROJECT**  
Twelfth Street:  
Hill Street to Market Street

**MOUNTAIN CROSS ENGINEERING, INC.**  
Civil and Environmental Consulting and Design  
826 1/2 Grand Avenue  
Glenwood Springs, CO 81601  
ph: 970.945.5544 | f: 970.945.5558 | www.mountaincross-eng.com



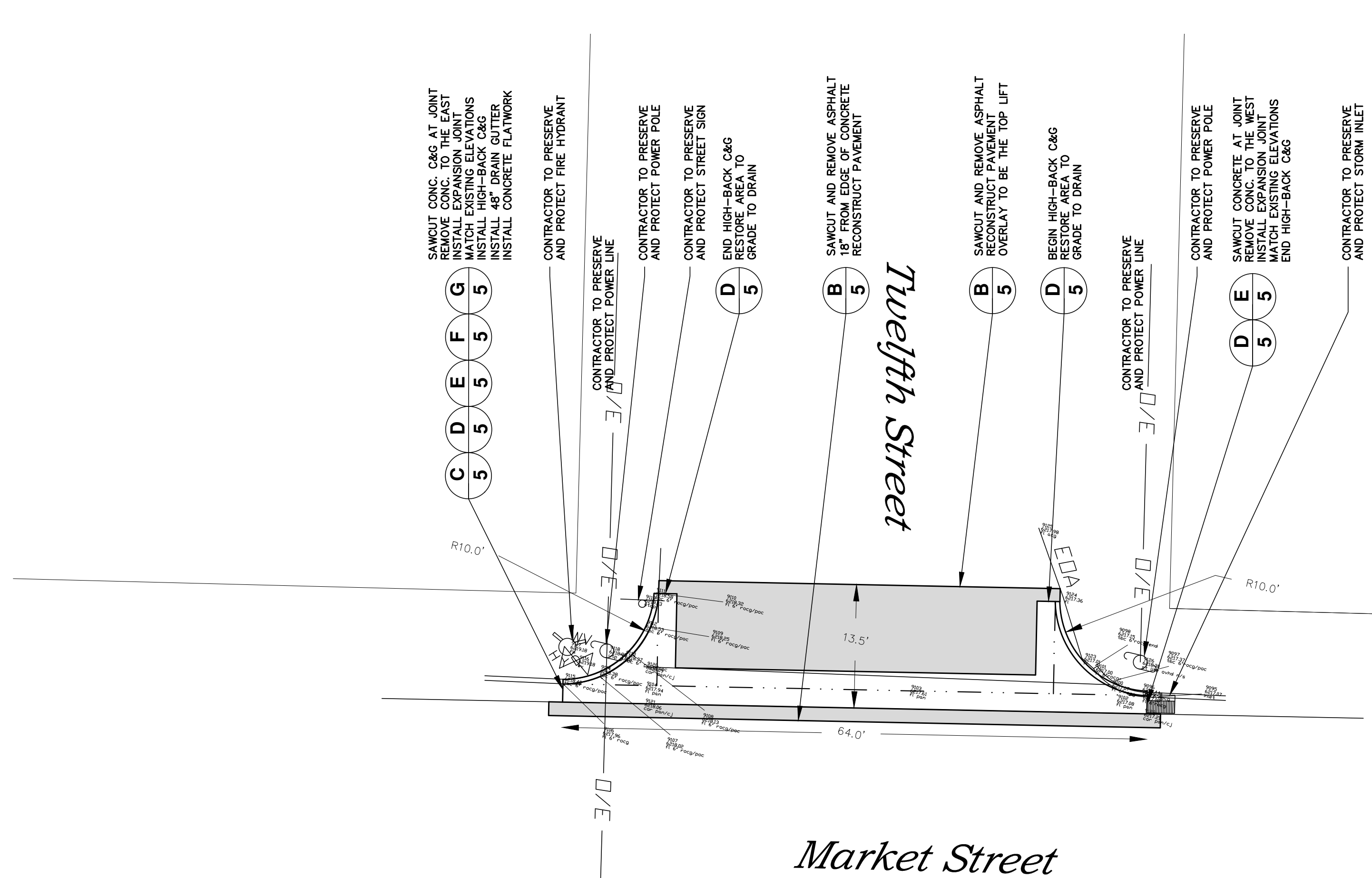
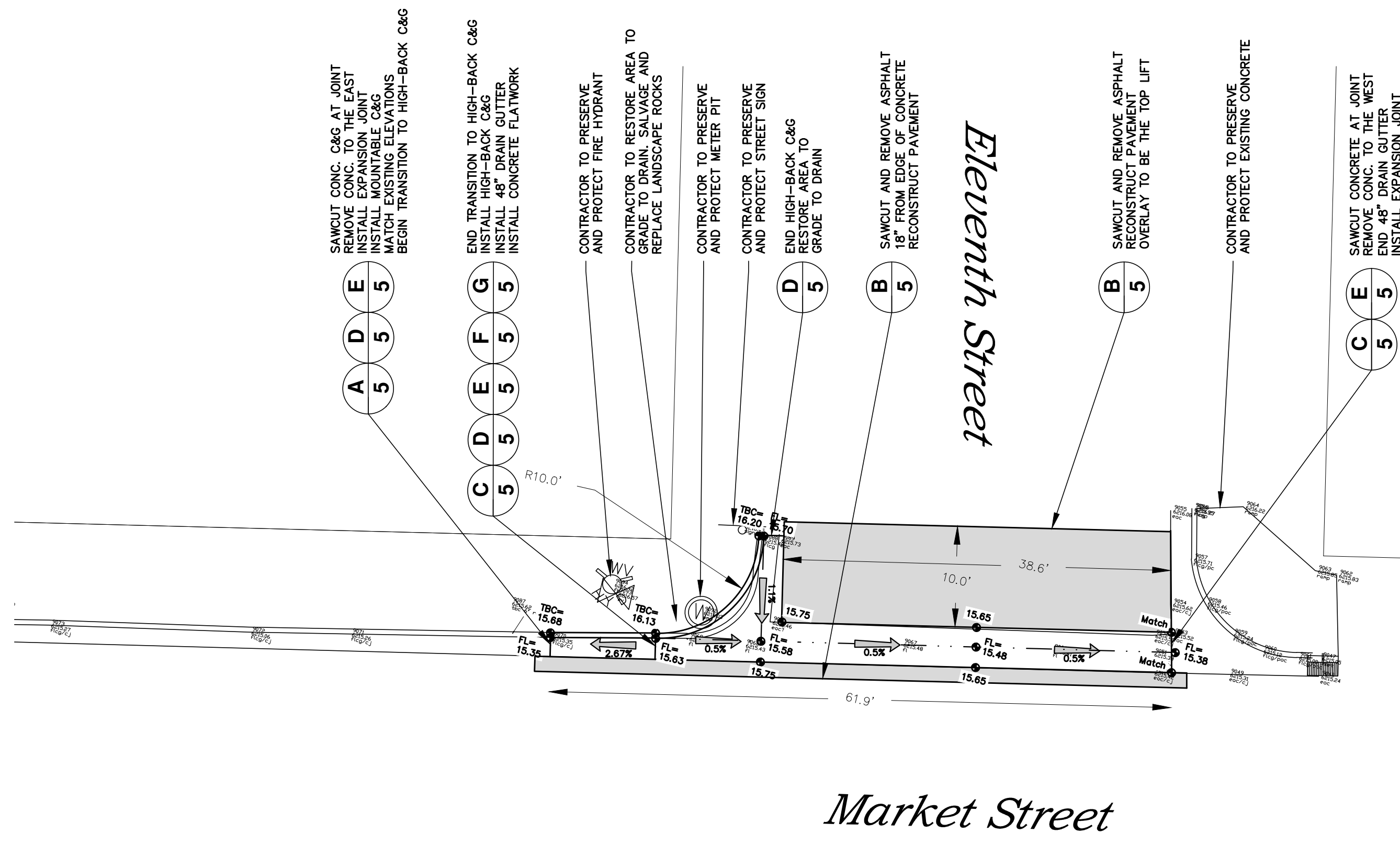

**PAVING PROJECT**  
**Concrete Replacement**  
**11th St. & 12th St.**



REVISIONS	DATE	BY	COMMENTS

DATE: 04/03/23  
 SCALE: 1" = 10'  
 ENGINEER: C. HALE  
 DWG FILE: 11th12thPaving  
 JOB: 319-058  
 SHEET: 4



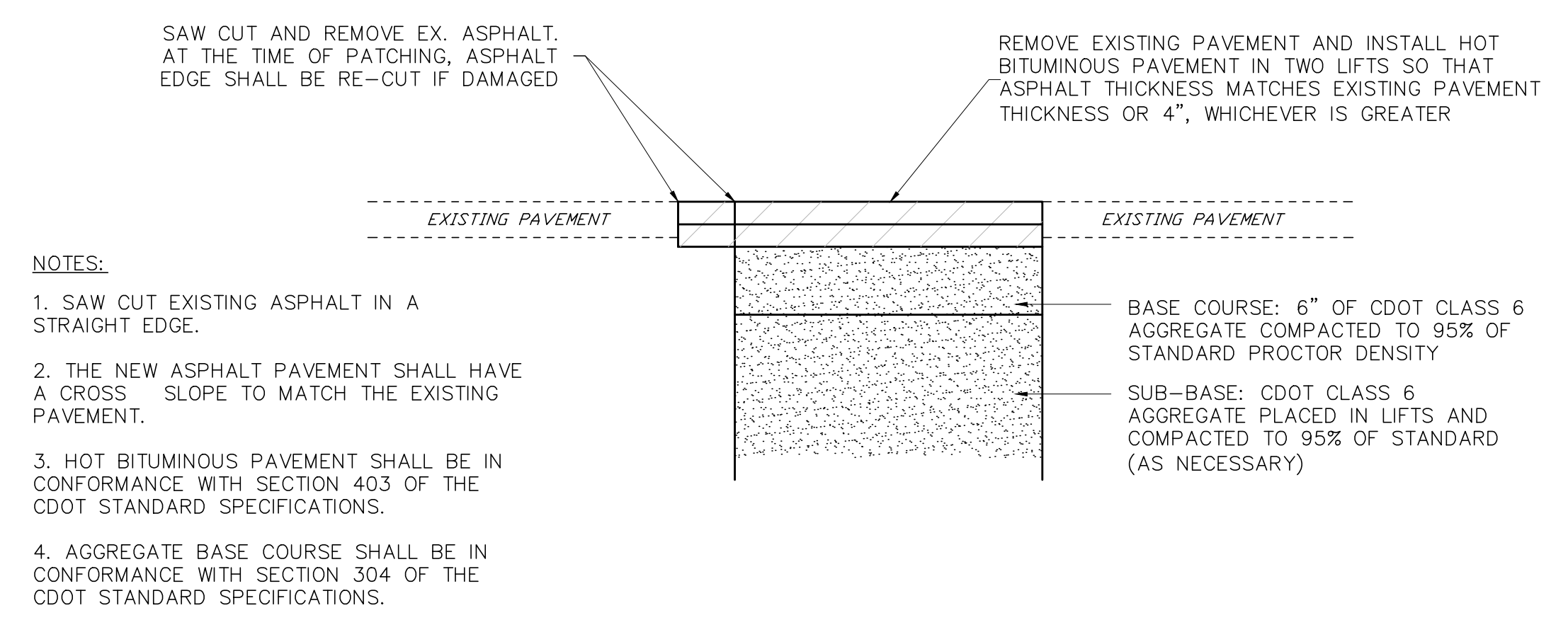
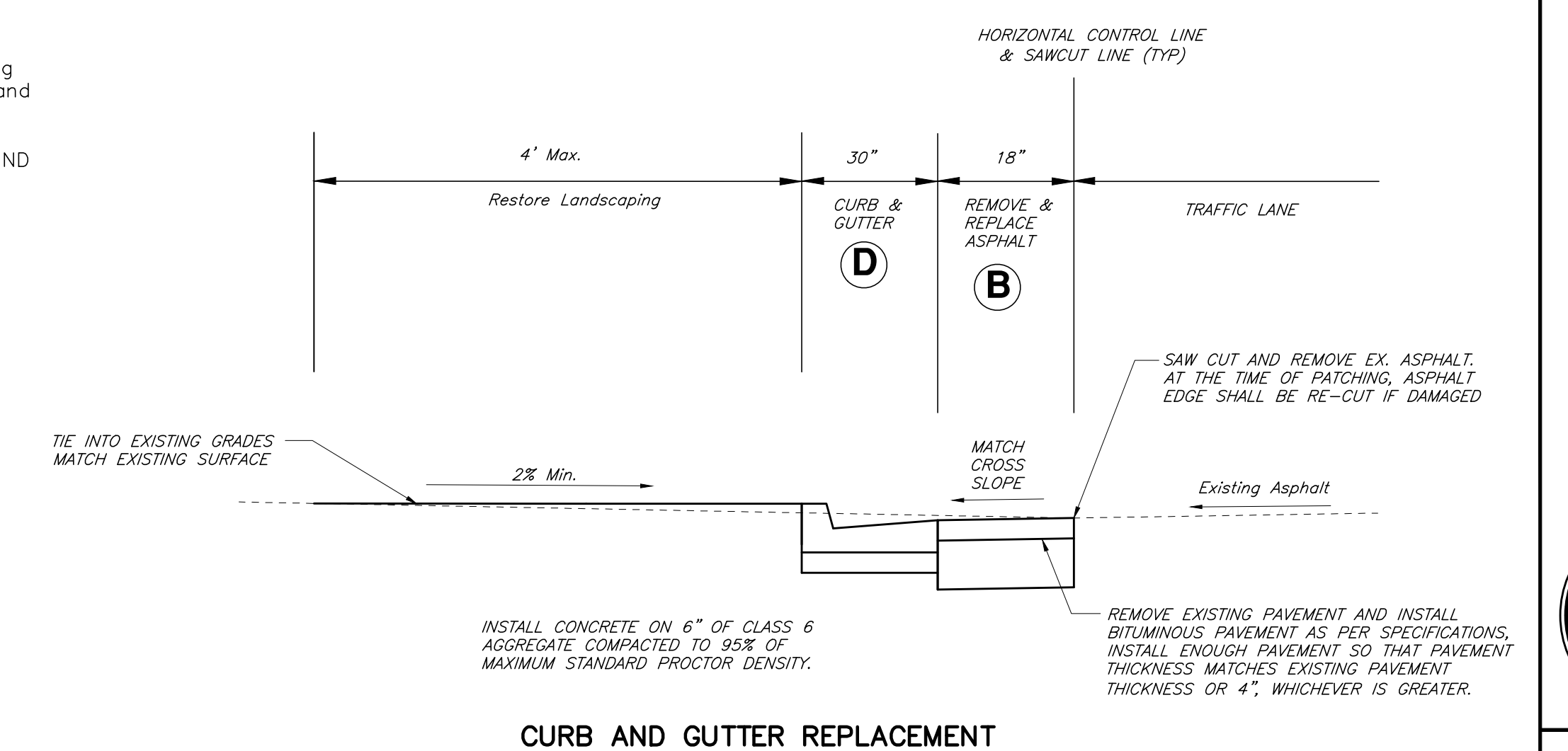
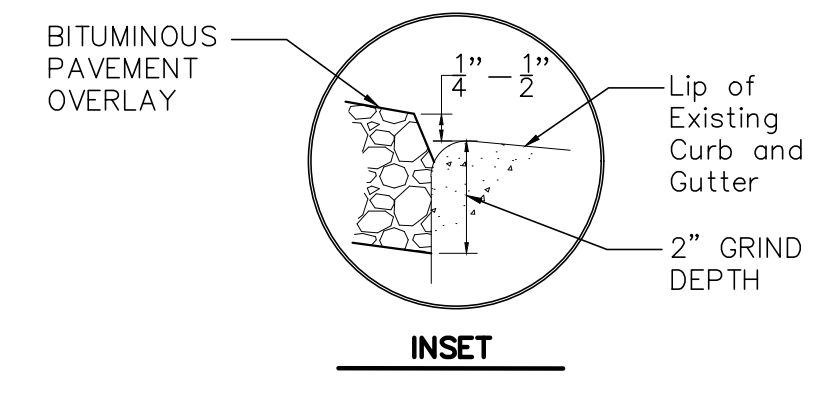
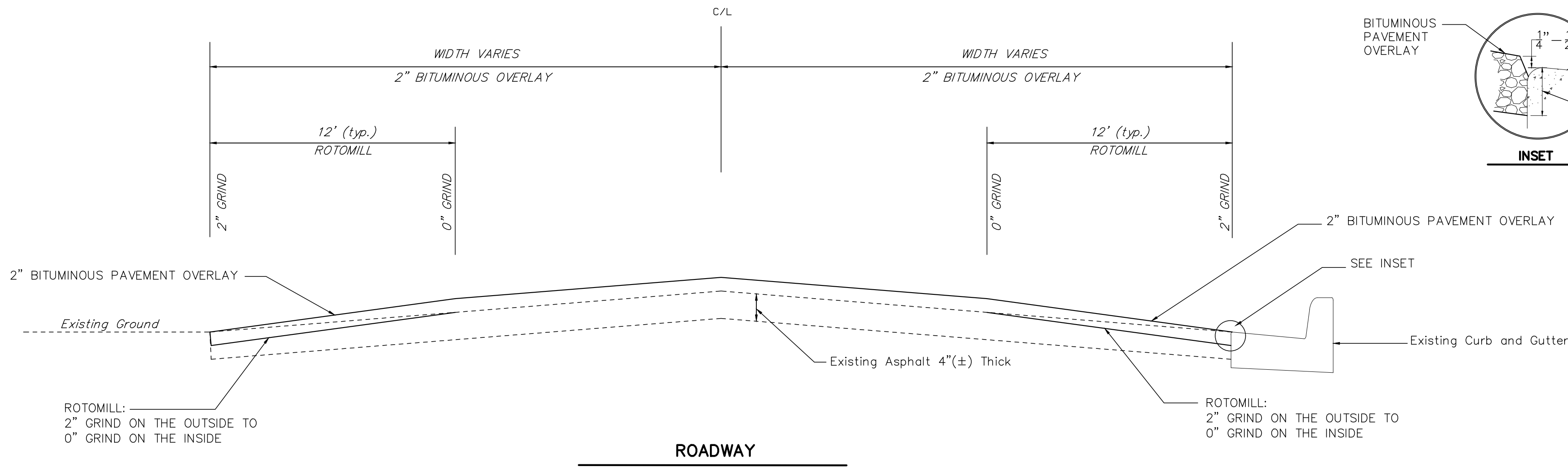

- NOTES:**
1. SAW CUT AND REMOVE EX. ASPHALT IN A STRAIGHT EDGE.
  2. THE NEW ASPHALT PAVEMENT SHALL HAVE A CROSS SLOPE TO MATCH THE EXISTING PAVEMENT.
  3. HOT BITUMINOUS PAVEMENT SHALL BE IN CONFORMANCE WITH SECTION 403 OF THE CDOT STANDARD SPECIFICATIONS.
  4. AGGREGATE BASE COURSE SHALL BE IN CONFORMANCE WITH SECTION 304 OF THE CDOT STANDARD SPECIFICATIONS.

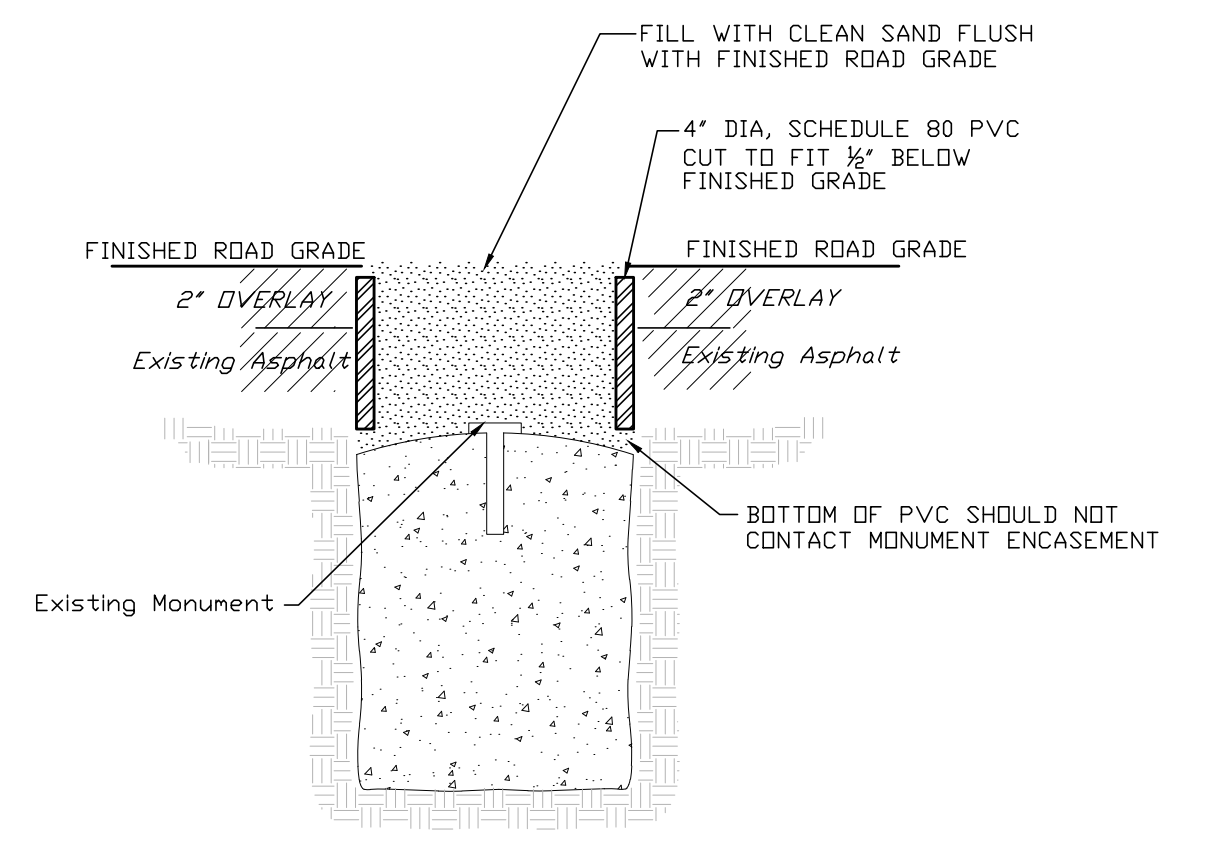
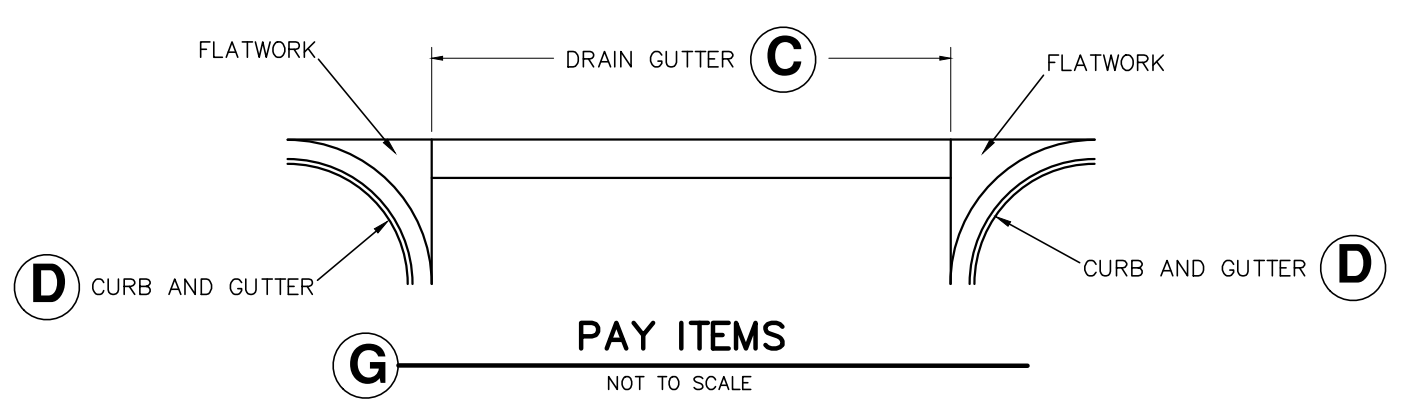
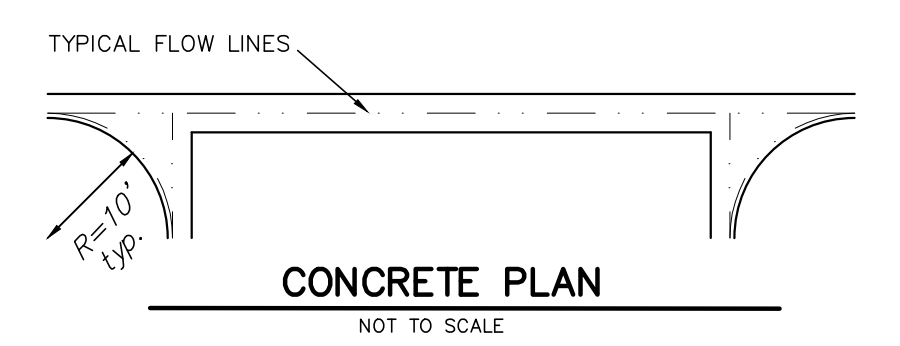
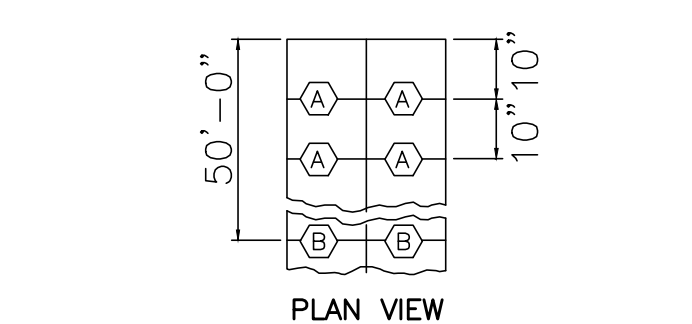
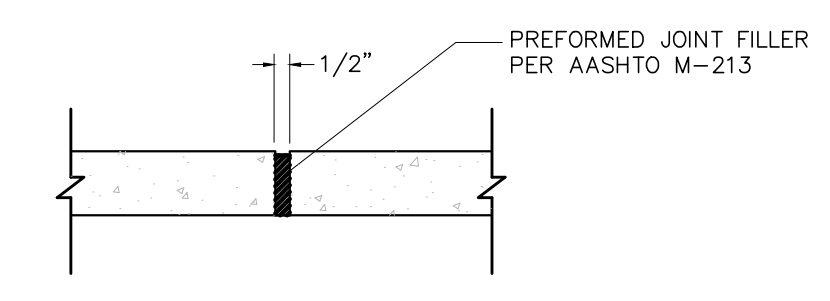
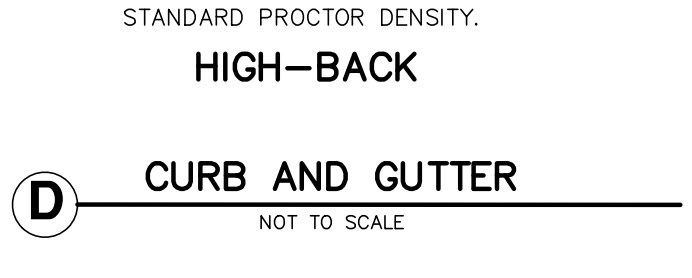
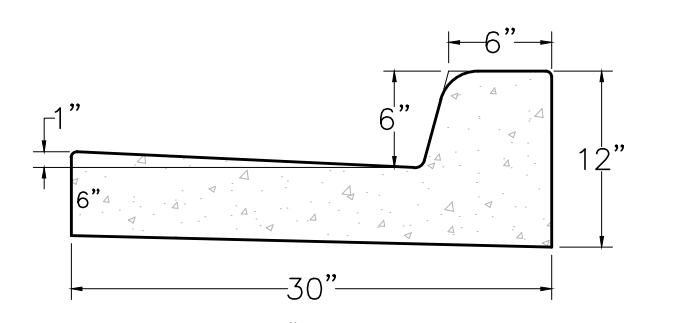
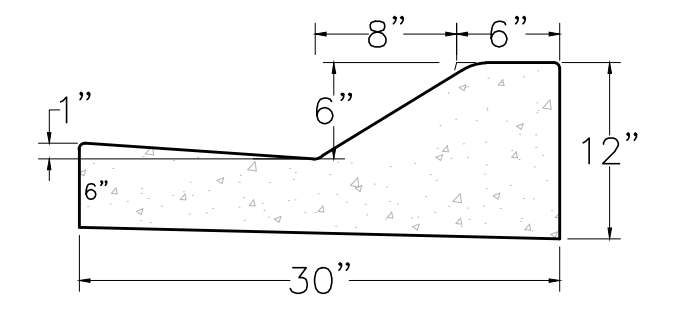
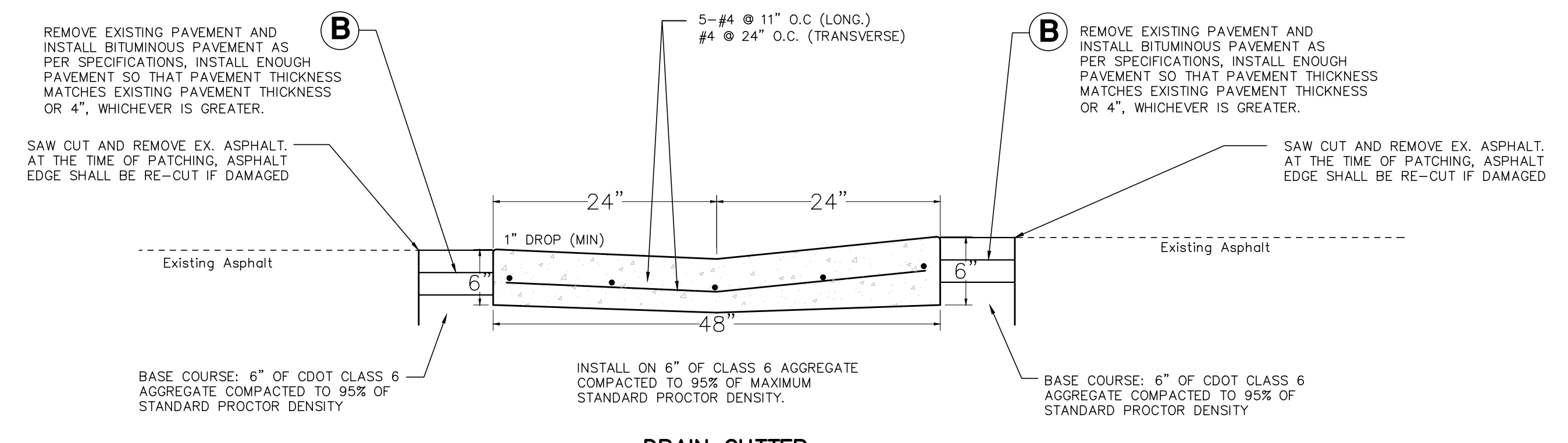

REVISIONS	DATE	BY	COMMENTS

DATE	04/03/23
SCALE	VARIES
ENGINEER	C. HALE
DWG FILE	11th12thPaving
JOB	319-058
SHEET	